

J. C. Humphreys  
and his  
Merrymeeting Bay Shipyard

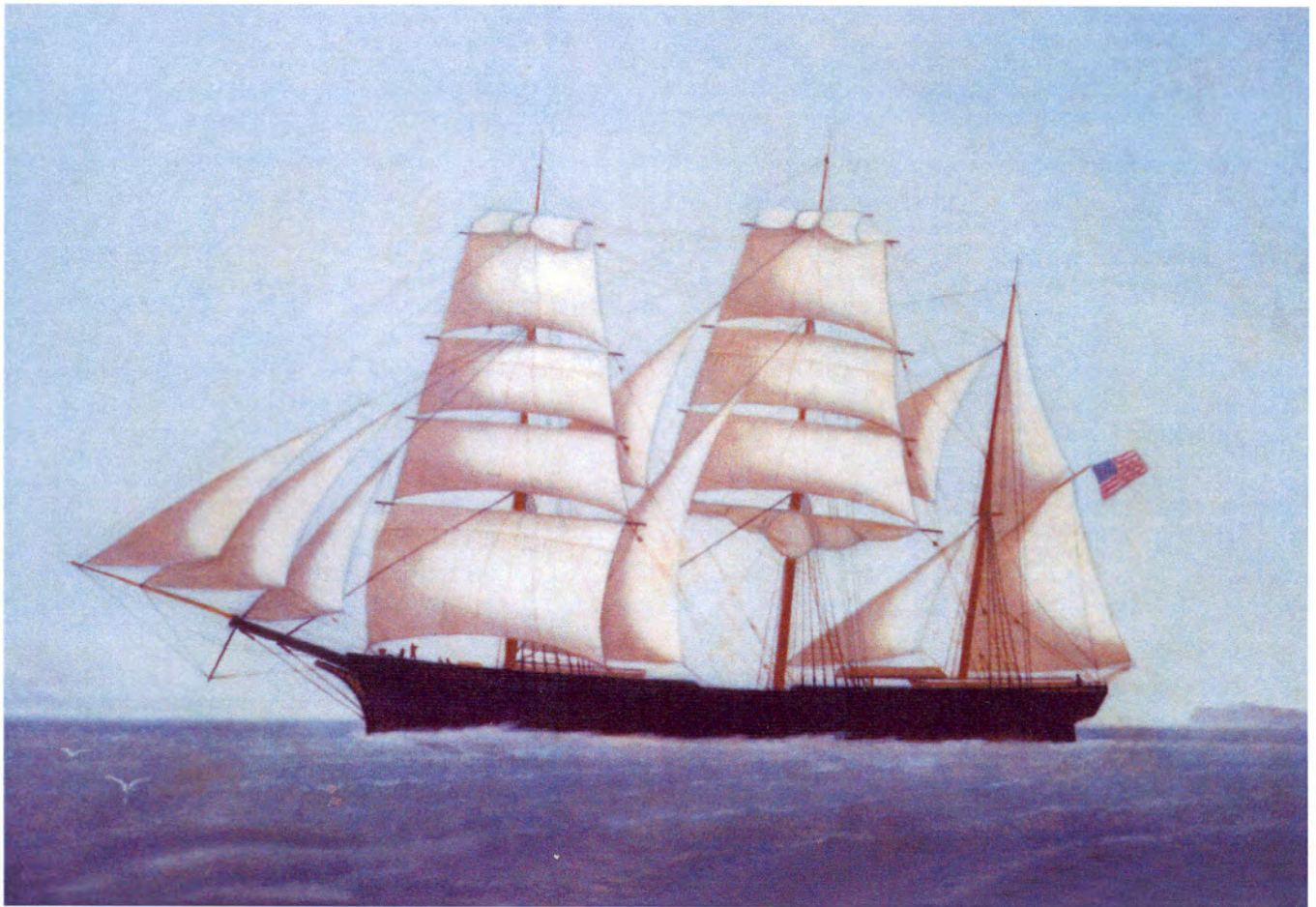

Christopher B. Gutscher

## Foreword

My purpose is to explore the life of John Campbell Humphreys of Brunswick, Maine. While little known today, in his time he was a well-respected Freemason and self-made businessman, politician and shipbuilder. He sired a large family, one of whom we shall learn a little about.

My interest in Humphreys comes from my earlier research on Merrymeeting Park, which was subsequently on the same site as Humphreys' last and most exciting venture, his steam mill and shipyard. I view this work as an ongoing project, not an end in itself, and hope it will generate more interest in this little-known shipyard.

Please join with me now and let us try to experience a little of the life and times of J. C. Humphreys.

## Acknowledgments

My sincere thanks to Gilbert Ormsby, Frank Moore, and Florence Galpern of the Ormsby family for their stories and facts, and for allowing me to wander the grounds all these years, and to the late Earl L. Ormsby for starting me on the path. I would also like to thank Robert Michael, Jr., for his typescript of the logbook of the *Annie Kimball* and the photograph of the *Annie Kimball* oil painting. Thanks also to Brian Cullen of the Pejepscot Historical Society for his help and for allowing me to photograph the half-hull models of the *J. C. Humphreys* and the *Ophir*. I would also like to thank Dick Snow and Fred Koerber for their research, guidance, and encouragement. Nathan Lipfert of the Maine Maritime Museum was of great help with his encyclopedic knowledge of all things maritime. Finally, my thanks to my wife, Dianne, for her editing.



**J. C.** (John Campbell) Humphreys is born in what is now Phippsburg, Maine, February 22, 1798. His father Lawrence (b. 1757) leaves Ireland as an adult to manage the plantation of a wealthy widow in Jamaica. Lawrence later sails as supercargo on a ship carrying molasses to Bath that wrecks on Parker Island, and he is stranded, penniless. He is befriended, eventually owns land there, and in 1788 marries Elizabeth (b. 1768) of the Campbell family. Lawrence and Elizabeth move to Topsham early in the life of their son J. C. At the age of fourteen the boy is already employed full time in Jotham Stone's store on Maine Street, Brunswick. Apparently he proves quite ambitious as, a few years later, J. C. and Ephraim Brown buy the stock and take over the business. The two young men run the business for several years as Brown & Humphreys (Wheeler 754, 839).

We next hear of Humphreys' enterprises about 1825 in partnership with Abner B. Thompson in the lumber and sawmill business. The firm of Thompson & Humphreys owns one of the many mills in the Cove in Brunswick, and this partnership lasts until 1850. Lumber is very big business in Brunswick at this time. Humphreys also is reported to have had a machine for sawing match blocks upstairs in his mill (Wheeler 562, 755).

A curious minor anecdote is mentioned in Louise Helmreich's book *Our Town*. Apparently two men stole some ideas from Humphreys' match-making machine to build their own. One of the men had a younger brother who was upset at his older sibling and made up a little ditty about the affair, and would sing it in front of Humphreys' store, to his great amusement (57).

Humphreys is a well-thought-of active citizen and a lifelong Democrat and Freemason. He first joins the United Lodge, Brunswick, in 1819 and quickly rises up the ranks (Wheeler 755).

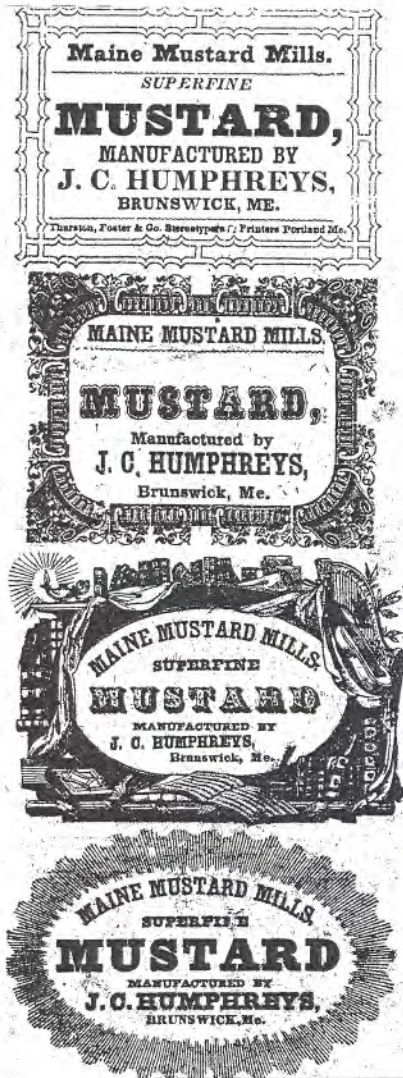

Labels used by Humphreys' Maine Mustard Mills in 1831. Presented by L. Mabelle Humphreys in 1889 to the Pejepscot Historical Society.

In 1822 he joins the Brunswick militia with the rank of captain. On the day before New Year's 1823, the up-and-coming 25-year-old Humphreys marries 20-year-old Angeline Whitmore of Bath. Their first child, John Henry, is born in February of 1825, the same year the boy's father is chosen lieutenant colonel in the militia. The next year, 1826, their second child, Charles C., is born. The ever-ambitious J. C. becomes a charter member of the first fire company in town, the Washington Fire Club. His name appears year after year in the Brunswick town records as chief fire warden. He also becomes a full colonel in the militia and rises to master of the Masonic lodge (Militia Records; Wheeler 755).

In 1828 he becomes one of the original stockholders of the Tontine Hotel, and the father to a new daughter, Angeline. By 1829 he attains the rank of brigadier general in the militia (Wheeler 295, 755). We can see his character developing as he joins and is promoted in various professional and fraternal organizations.

Humphreys adds another business to his various enterprises about 1830. He establishes the Maine Mustard Mills in the upper part of his sawmill in the Cove. He develops this business to such an extent that it enjoys a national fame (Wheeler 571). In a letter in 1845 to Silas Pierce, one of his suppliers, he writes: "the first shipment of yellow and brown [seed] has been received, and the second lot of brown I understand is to be shipped by the first Brunswick packet. ..." Later in the same letter he orders 85 bushels of white seed.

He becomes president of the Nucleus Club in 1830. Wheelers' History states that of the numerous literary and scientific associations in the three towns, "the Nucleus Club ... deservedly takes the highest rank." The couple's fourth child, Lovice, is born that same year (242, 755). By 1831 J. C. attains the rank of major general in the militia and he is honorably discharged two years later in 1833 (Militia Records).

In both 1832 and 1833 Humphreys is appointed Deputy Grand Master of the 1st Masonic District. His family continues to grow and two more sons, George and Frederic, are born in 1833 and 1836, but both die as teenagers in 1851 (Humphreys Genealogy 9, 21).

In 1834 Humphreys is one of the incorporators of the Brunswick Company. Its purpose is to manufacture iron and steel and to process cotton and wool. The company owned nine mill sites, assorted dwellings, houses and stores, and 13½ acres of land as well as the river with islands and dams (Wheeler 565). Curiously there is no estate or income tax listed for Humphreys in 1834 even though he is married with a family and 36 years old (Brunswick Tax Records). A year later J. C. buys an existing water-pail manufacturing business originally owned by Houghton and Crane (Wheeler 571).

In 1836 he becomes one of five directors of the Brunswick Bank. He begins his active political life by becoming a Brunswick selectman in 1837 (Wheeler 575, 923). In 1838 his seventh offspring and fifth son is born. He names him Denny McCobb after a close older friend. Denny attends Brunswick schools and then is sent to finish his education at the Abbott School, Little Blue, Farmington. This son is destined to be one of his father's business partners and eventually the captain of one of the family's ships (Humphreys Genealogy, 1). One year later, in 1839, J. C. is elected a state senator (Wheeler, 916).

John C. Humphreys lived in a time and place not favorable to some of his views. He was a staunch Democrat in a town where that party was in the minority. He was a Mason at a low point in that organization's popularity. He also was an abolitionist and not afraid to speak his mind. In October 1838 there was a sharp struggle in Brunswick over the question of publicly discussing the subject of slavery. A meeting was held to consider the matter and an attempt was made to railroad through resolutions already prepared unfavorable to the abolitionists. Professor Smythe of Bowdoin demanded a discussion. There were hisses and cries of "Down with him!" but the professor was not to be daunted. General John C. Humphreys came to his support and the meeting adjourned till the 30th without action (Wheeler, 234).

The 1840 census lists his household as having ten members, with four being employed. One is listed as 25 years or older who is "deaf and dumb," but this person is too old to be one of his own children.

The two portraits we have of John Campbell Humphreys (next page) make him out to be a serious fellow. He appears to be a straight shooter and in 1841 becomes president of the Washington Total Abstinence Society of Brunswick. A few years later in 1845 he becomes one of seven trustees of the 169-student Brunswick Seminary (Wheeler 253, 477).

His last daughter, Huldah, is born in 1842 (Humphreys Genealogy, 9). His total Brunswick tax valuation for this year is \$12,046, making him the fifth wealthiest man in town (Brunswick Tax Records).

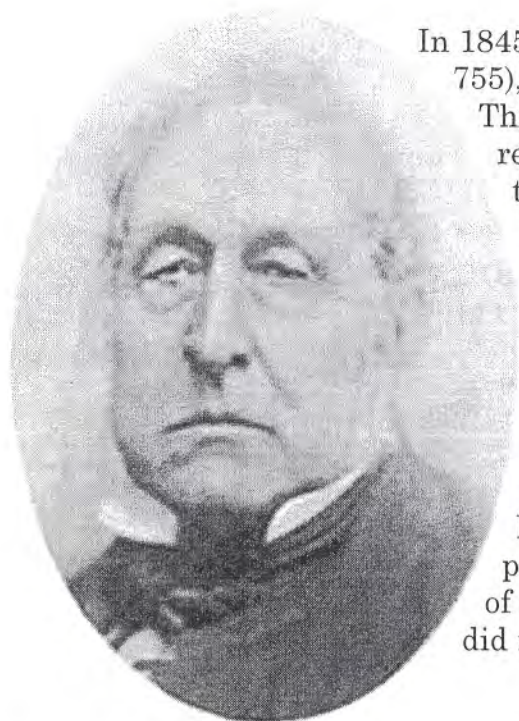

Above: Photograph of J. C. Humphreys (courtesy of Brunswick Masonic Lodge)

Right: Engraving and signature of J. C. Humphreys (Wheeler)

In 1845 he is appointed collector of the port of Bath (Wheeler 755), and he brings his son John Henry to the job with him. This is not a hugely stressful job, but he would have been responsible for the documentation of all ships passing through the port of Bath. There may have been one hundred ships to and from foreign ports, and perhaps one thousand ships to and from U. S. ports. Bath at this time was the fifth largest port on the east coast. J. C. also would have been responsible for registering all vessels home-ported in the immediate area. The collector worked from an office in the Bath Bank building on the corner of Front and Centre streets, not the building we now think of as the old customs house. This was to have been a four-year Federal patronage appointment, but as can be seen by excerpts of a lengthy 1853 letter to Governor John Hubbard, all did not go well, and he is upset:



*Very truly yours  
J C Humphreys.*



The Bath Customs House had an office in the Bath Bank building on the corner of Front and Centre streets (courtesy of Maine Maritime Museum)

*Brunswick, Feby 1-1853*

*Hon John Hubbard, Dear Sir,*

*I feel under very great obligations to you for your favorable consideration of my application for the Collectorship of Bath. Also for your disposition to help me in regard to the matter.*

*I am extremely anxious to have the President understand my precise position. I was appointed for four years by Mr. Polk, held the office untill the election of Genl. Taylor, only a little over two years. I was removed by Genl Taylor at once on his coming into power. I have never heard any complaint made of my administration of the affairs of the office, either by Whig or Democrat, and I presume my being reinstated again would be as generally satisfactory as the appointment of any other person except to a few loafers who are hanging on to the skirts of some two or three prominent candidates for the under offices. I have given no pledges for those offices if I receive the*



appointment, I shall be perfectly independent. My having held the office for some over two years only is one reason and I consider a good reason why I should be placed back. I hold that there are customs & usages of the party that are vital to its interests & existence. One very important one is the usage of supporting regular nominations. The violation of that usage the present year in our own Democratic State by unprincipled men who are determined to "Rule or Ruin" shows clearly to my mind the danger of such violations.

It was formerly a usage of the party to give an officer two terms, or eight years, latterly it seems to have got reduced down to one term, of which I do not complain, but I have supposed that half terms are not yet in fashion. I am willing to go into the one term system but that term I want, and I think custom & usage will give it to me. ...

The President\* has some knowledge of me, probably knew me when in college, and I have no doubt if he takes the subject into mature consideration, he will with your representation give me the appointment. So far as other recommendations are concerned I can point to every leading Democrat in Maine, and they must admit that my whole life time [h]as been devoted to the Democratic cause in the old Federal Town of Brunswick, and a constant battling for Democratic principles under discouraging circumstances, being always exposed to talented influences against us.

It can be seen from the above letter that he has friends in high places and knows the political landscape. This is a man of power and influence who has certain expectations for himself and his party.

Another example of his stature is a letter from Asa William Henry Clapp, at his Washington office, to Humphreys. Mr. Clapp was a representative from Maine, and elected as a Democrat to the 30th Congress at the time of this letter.

Washington  
Dec 20th 1847.

Dear Sir –

Yours of the 14th is rec'd and I am pleased to say that I think with the exception of Gov. Fairfield our Delegation will be united for Gov. Dunlap. Gov Fairfield informs me however that he shall remain neutral.

I shall leave for home the last of the month when I shall be enabled to give you further particulars.

Most  
Truly yours  
AWH Clapp

Gen. J. C. Humphreys  
Brunswick  
Me

---

\*Then-president Franklin Pierce graduated from Bowdoin College in 1824.



Left: House owned by J. C. Humphreys at 42 Federal St., Brunswick. Below: House owned by J. C. Humphreys at 17 Federal St., Brunswick (photos by author)

C. J. Noyes' Brunswick map of 1846 shows that Humphreys has four real-estate holdings in the downtown area. He owns buildings at the corner of Stone and Water streets, at Maine Street near the Cove, at the corner of Federal and School streets, and another on the east side of Federal between Bank and Centre streets. The two homes on Federal Street are still there.



His last child, James, is born in August of 1847, but Humphreys' 15-year-old daughter, Lovice, dies in November of that same year. In May of 1848, the infant James also dies (Humphreys Genealogy, 9). Brunswick tax records show J. C. to have slipped slightly in his total worth, and he is now sixth wealthiest man in town.

In October of 1847 J. C. Humphreys buys the 95-acre Dunning farm for \$1,600. This splendid parcel of land is about two miles east of town and extends from what was to become the Bath Road, all the way to the Narrows on the Androscoggin River. In 1848 he moves his lumber mill, home, family, and entire business operation to the new site. It is here that he erects two large sawmills powered by two very large steam engines. As the land was referred to as the Dunning farm, it probably had little wooded acreage for his mill, but, being on the river, he had access to timber from the log drives on both the Androscoggin and the Kennebec (Rowe, 123).

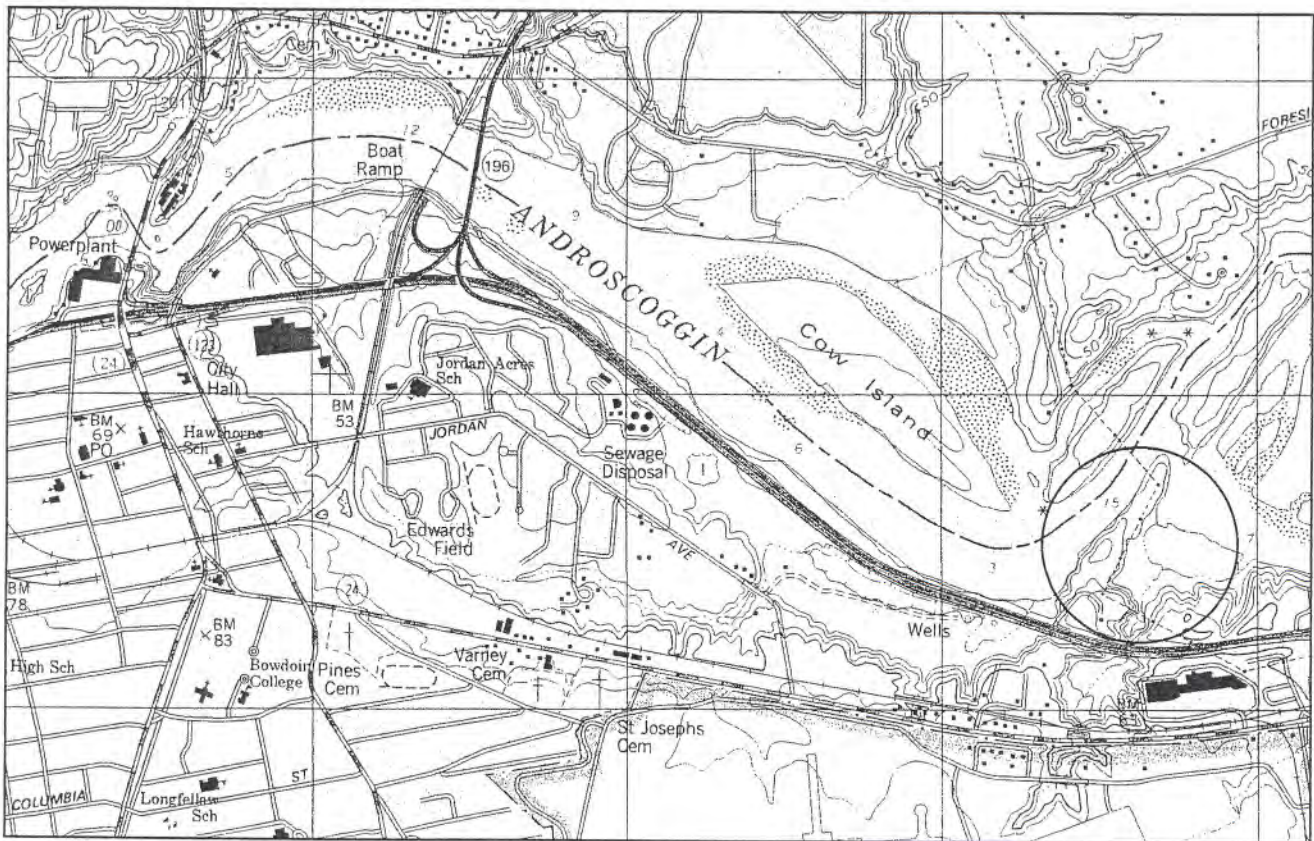

Modern map showing Brunswick and environs. Location of Humphreys' business is in circle at right.

As there are no steam sawmills left from the mid-19th century, it's difficult to know the size of the buildings, even though we have a list of the individual saws. What we do know more certainly is the size of the steam engines, judged by the 17-inch diameter cylinders that powered each one (Wheeler 561). A cylinder of that size might have had a 4-foot stroke, and the engine would probably have had a flywheel eight to ten feet in diameter with curved spokes, and weighed many tons. It would have probably been a horizontal box-bed design, capable of producing 75 to 100 horsepower, and run at a low r.p.m. These engines were probably manufactured somewhere in the northeast United States or perhaps even in Maine. In 1848, steam power was modern cutting-edge technology. Although this site was on a river with the potential to use its current, these engines would have produced far more power than could be harnessed from the river. Quoting from the book *Brunswick: A Sketch of the Town*: "Here was once a saw mill of which there are no traces save a few stones and great heaps of saw-dust, but such is the force of local usage ... that the place is usually spoken of as Humphreys Steam Mills." (43)

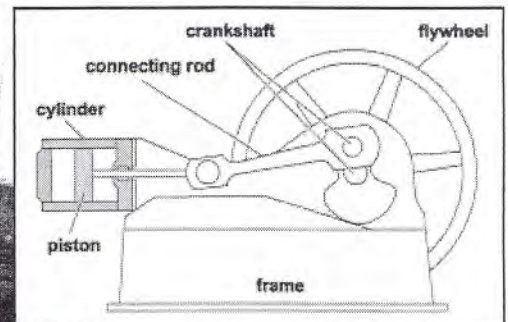
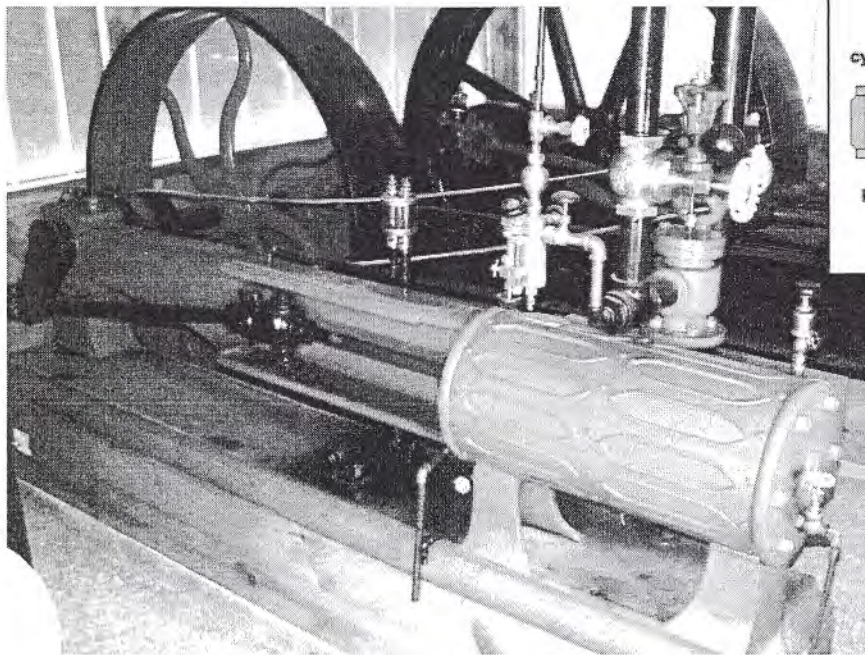
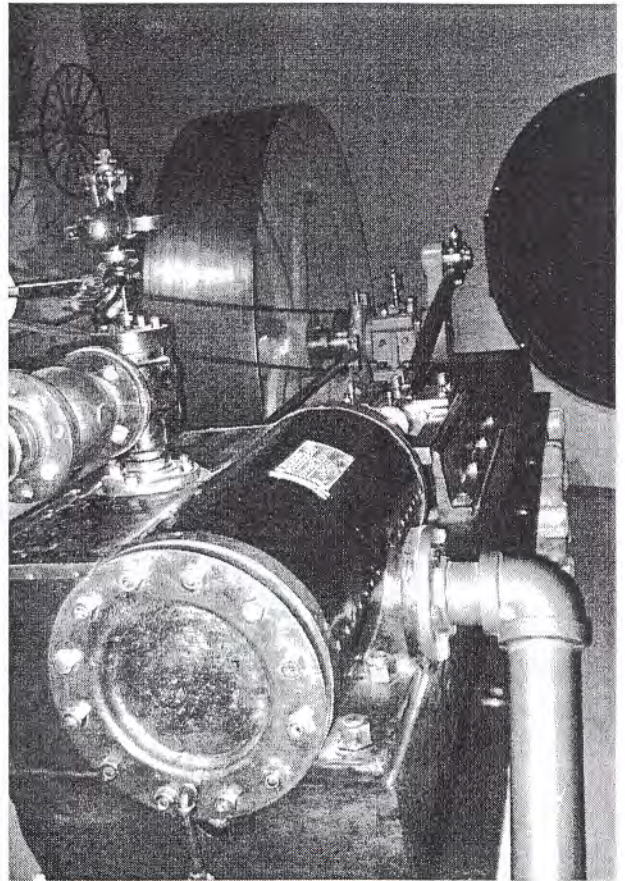

Top: Photograph of 12-inch diameter cylinder, 30-inch stroke Portland Co. steam engine as seen at Maine State Museum (photo by author)

Above: Simplified drawing of steam engine

Left: Restored small steam engine (Charles Chiarichiaro Collection)

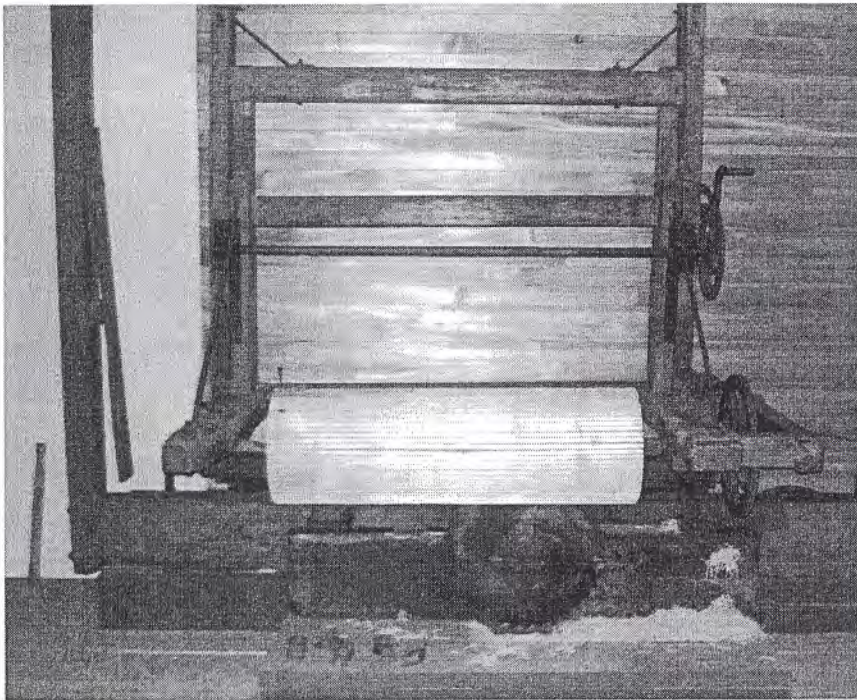

Above: Clapboard saw as it might have been used at Humphreys saw mill (Maine State Museum, photo by author)

Below: Photo of Charles Humphreys, son of J. C. Humphreys (courtesy of Maine Maritime Museum)

Right: Detail of 1858 map of Sagadahoc County (courtesy of Patten Free Library)



These two huge engines drove:

1. one gang saw
2. two upright single saws
3. two shingle saws
4. one clapboard saw
5. one lath machine
6. one machine for making molasses hogsheads
7. two machines for making shooks
8. edging, cutoff, and other saws (Wheeler 561).

The two steam mills were a very large expansion in his business. The Wheelers say

he was in company with his sons, John and Charles, who were now young men of 22 and 23 years of age (755). One of the buildings on the "Humphreysville" detail of Chace's map, shown below, is labeled "boarding house," which probably was for the workers employed at the yard.

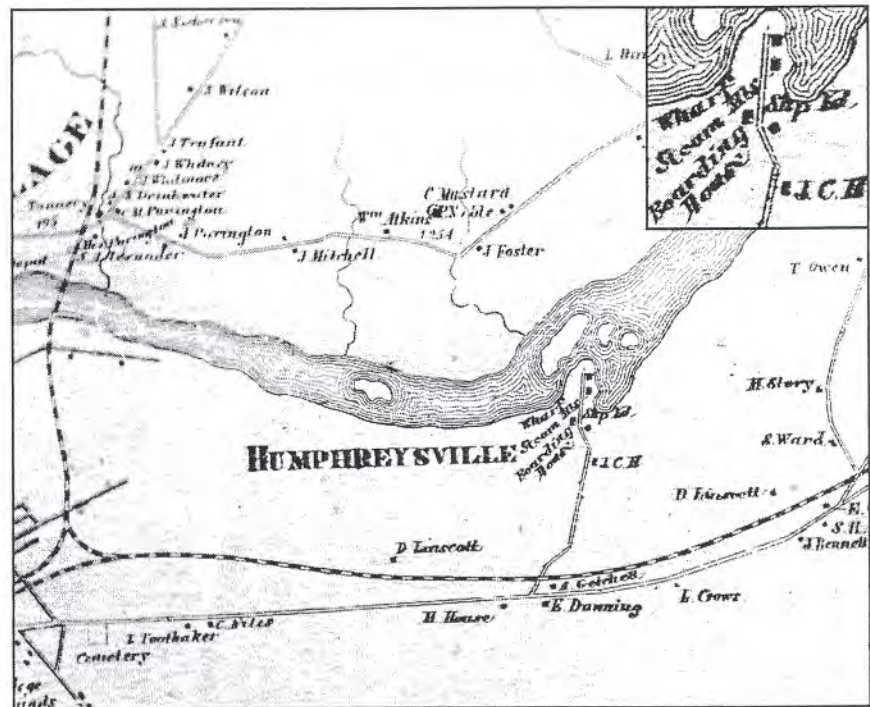

Inset in above illustration shows close-up of buildings at Humphreysville. To left of road, top to bottom, are "Wharf," "Steam Mills" and "Boarding House"; to right of road are "Ship Yd" and "J. C. H.," or the dwelling of John Campbell Humphreys.

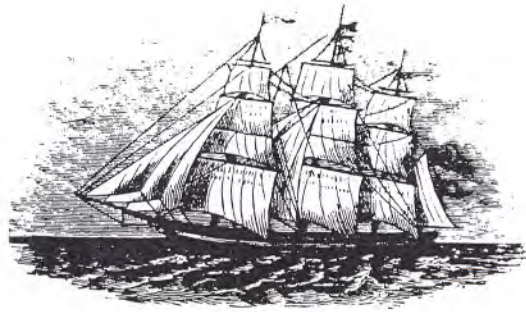

More exciting than the growth of his existing business is the start of a completely new venture: shipbuilding. In the past his mills have probably sold wood to shipbuilders, as shipbuilding was a popular and profitable venture at this time. There were many shipyards up and down the coast and inland, at communities like Bath, Bowdoinham, and up the Kennebec as far as Augusta. The family gets into the shipbuilding business a little on the late side of the boom, but they have the advantage over many yards by having two large sawmills at their disposal. J. C. is now 50 years old, experienced in business and politics, but even with his sons' help, shipbuilding would have been a big step.

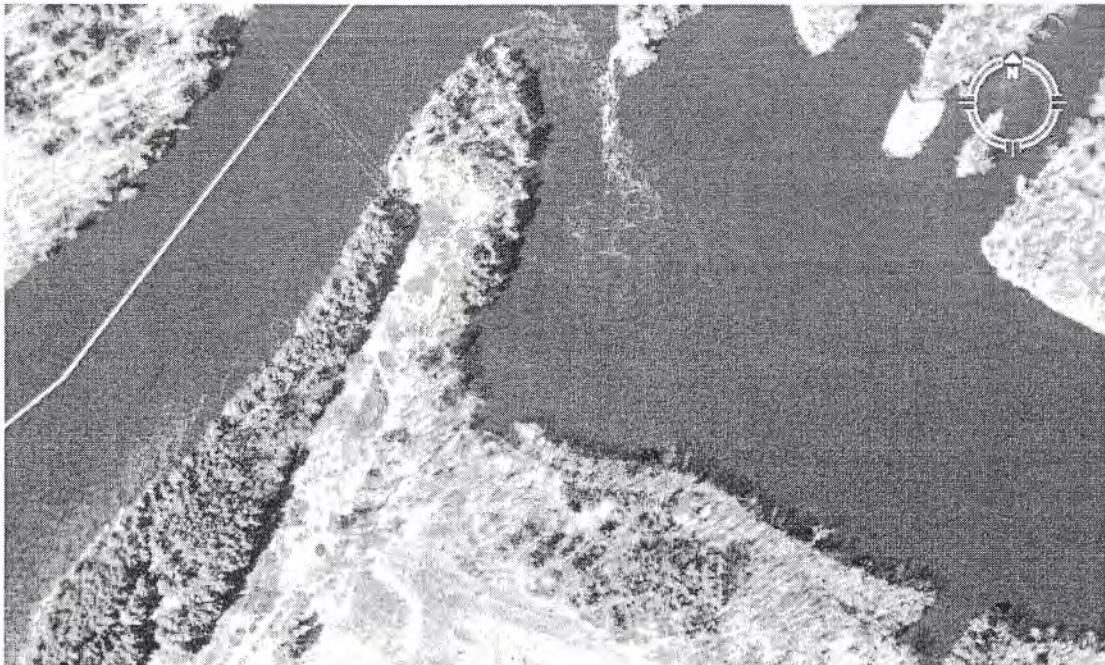

Google photo showing close-up of sawmill and shipyard site in Androscoggin River

In his first year of operation, 1848, he launches the ship *Ophir*. She is 122 feet long with a beam of 28 feet and a draft of 14 feet. The builder is listed as E. Hunt and the master and owner H. Sylvester. Owners and builders often sold off fractions of ownership in a vessel to defray building costs. There are two accounts of her over the years sailing under different lines, under different captains, but both reports are of her sailing the New York to New Orleans route, likely carrying cotton. It is interesting to speculate whether his abolitionist views of ten years ago are tempered by his present status as a ship owner. If the southern states could not produce cheap cotton, he would have less cargo to carry in his ships.

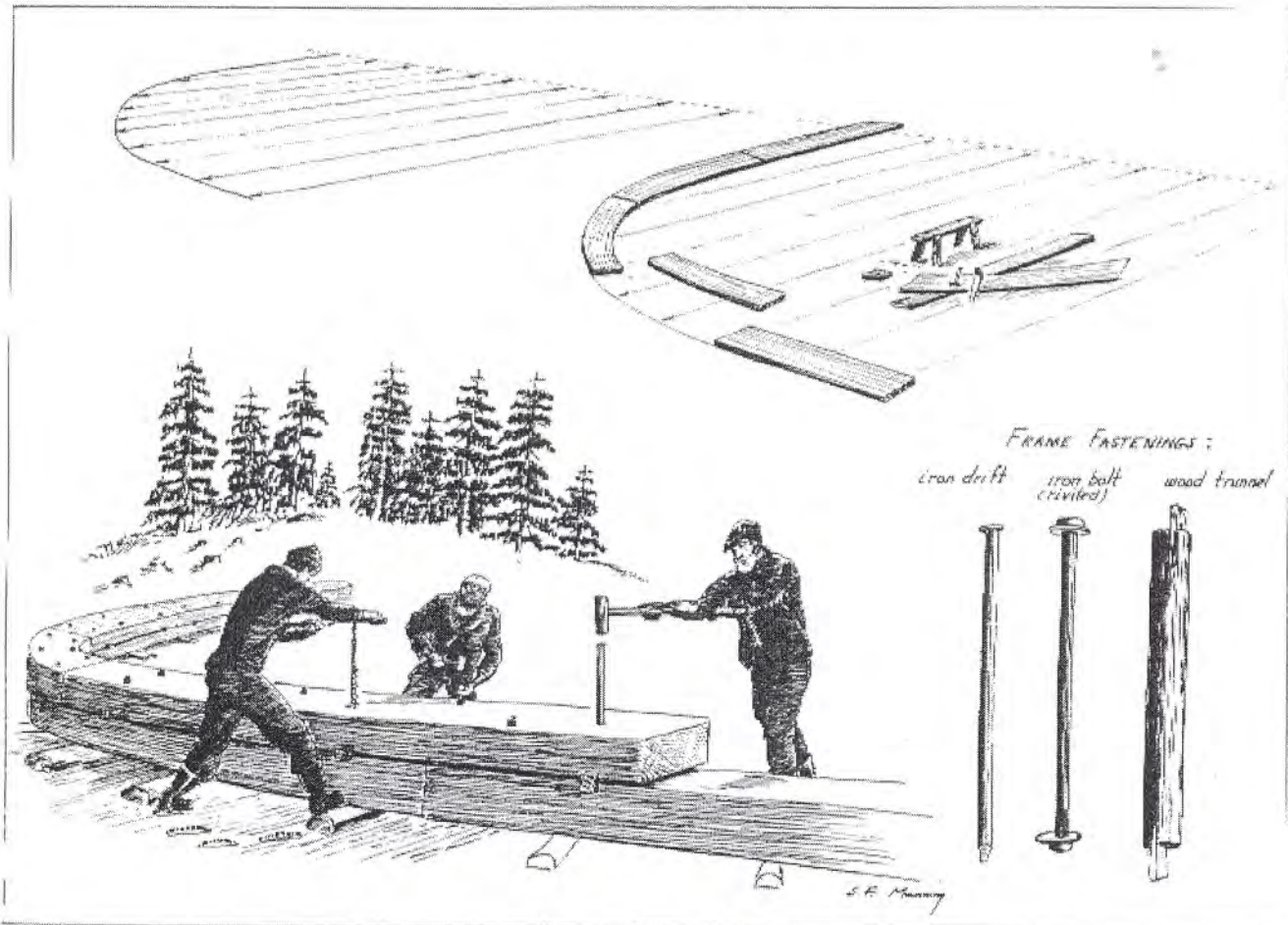

Offsets from the half-model, board templates and frame futtocks. Line drawing of building frames by S. F. Manning (courtesy of Pejepscot Historical Society)

Like many vessels of the time, *Ophir* was probably sold and bought many times as years passed. Captain and crew of a ship of this size would probably have numbered 18 to 20 men. The crew would have changed time and time again, and, as the ship aged, she became less profitable to repair and sail. Often, before a vessel attained any great age, it would be lost in a storm, or wrecked on a reef or rocky shore. The average life span of a sail-

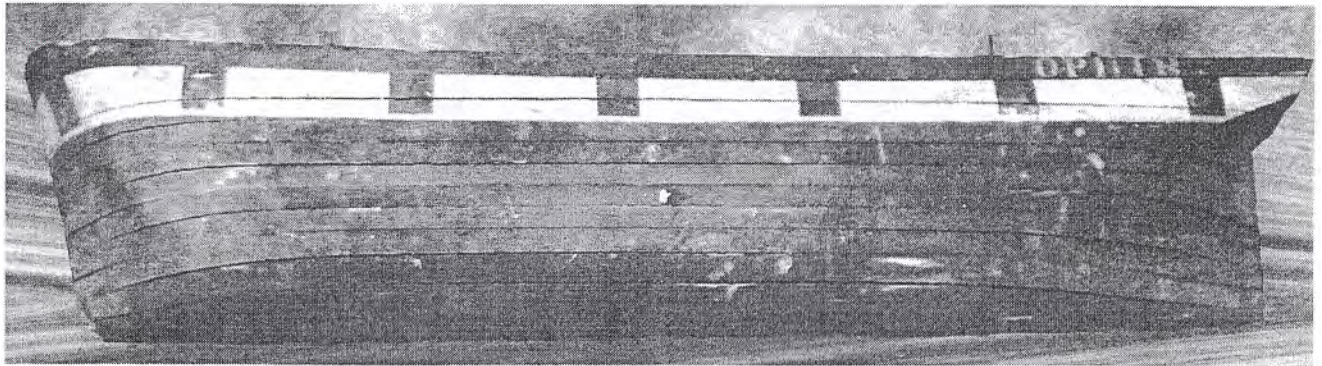

Half hull model of the ship *Ophir* (courtesy Pejepscot Historical Society)

ing ship of this time was approximately 12 years. *Ophir* sailed for nine years and met her fate in an 1857 grounding, as told in Portland's *Eastern Argus* in a notice of February 3:

Ship *Ophir* of and from New York for New Orleans wrecked at Key West, was built in Brunswick, in 1848, 438 tons rated A2, and was insured in New York and New Orleans. She had a general cargo, principally dry goods, valued at \$100,000, which is understood to be covered by insurance at various places. (4)

Although he is heavily involved with his large new venture, politics is still on J. C.'s mind. He is corresponding with Charles Andrews, who at the time was a delegate to the Democrats' national convention and the clerk of courts for Oxford County. Previously Andrews was a United States representative, serving as Speaker of the House in 1842.

The shipbuilding enterprise must have gone well, as the yard builds another ship the next year. This one bears his own name, *J. C. Humphreys*, and is larger than *Ophir*. J. C. is listed as the owner, with Ephraim Hunt as builder. She is 140 feet in length with a 29-foot beam and a draft of 14 feet. In November of 1854 *J. C. Humphreys* carried two German immigrant families from Antwerp to New Orleans (Ficken). A short report in the April 10, 1857, *Brunswick Telegraph* states that she is in New Orleans, probably loading cotton (2). In the 1850s, cotton, often carried in Maine-built ships with Maine captains, was a major U. S. export. In April of 1861 this ship is leased to Hong Kong merchants for twelve months for "voyages between ports lying east of the Cape of Good Hope or on the Pacific Ocean" (Janus).

The 1850 census now shows ten persons living in J. C.'s household including his 83-year-old mother, Elizabeth. Also listed are Ann Gould





Half hull model of ship *J. C. Humphreys* (courtesy Pejepscot Historical Society)

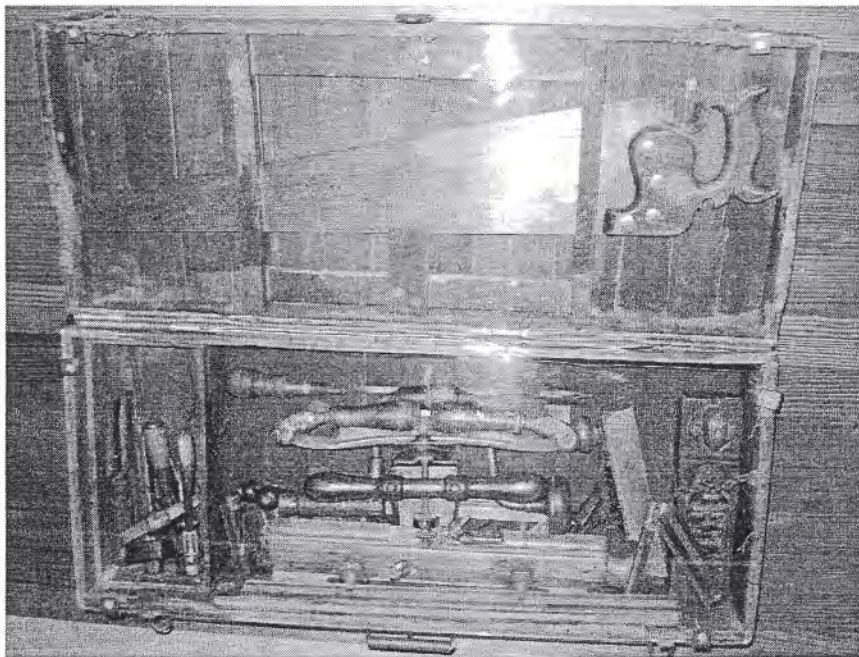

Toolbox and hand tools of typical 19th century shipbuilder (Maine State Museum, photo by author)

of Massachusetts, five years old, and Bridget Broderick, born in Ireland, who was probably a servant. In 1851, he is elevated to Grand Master of Masons in Maine, a very high position. He also petitions the

Brunswick selectmen to build a town road to his property (Brunswick Selectmen Petition). This is likely the road that is the present entrance to the auto salvage yard and concrete plant on the Bath Road. I assume that as his business increases, he needs a better road leading from "the turnpike." He continues to build larger vessels, and the next one he names *Singapore*, perhaps with the expectation of foreign travels and commerce.

Humphreys is listed as the owner and E. Hunt is again the builder. There is a short newspaper account of the weekend launch:

*Eastern Argus* (Portland), July 8, 1851

Launched, at Brunswick, on Saturday last, from the ship yard of Gen. J. C. Humphreys, Bath, a fine ship of about 600 tons. She is built of seasoned timber, in the most substantial manner, and heavily fastened throughout. Her owners are Gen. Humphreys and C. B. Fessenden of Boston, and is intended for the East India trade. Capt. Hamilton, of Chatham, Mass., is to command her. (2)

An 1898 *Brunswick Telegraph* article, "We Built Ships," reported that thirteen ships were built in Brunswick in 1851. Carpenters' wages were from three to four dollars a day and about six hundred men were employed in the various shipbuilding trades (1).

There is a news story in the January 21, 1854 issue of the *New York Times*: "The Lost Ship Singapore – Safety of the Crew. Boston, Friday, Jan. 20. The Captain and crew of the ship *Singapore*, of and from New York for Antwerp, before reported lost, were taken into Liverpool, N. S., by the British bark *Sylph*, Captain Roberts." (1). This ship only sailed for two and one-half years, and its loss was undoubtedly a financial blow to Humphreys.

Humphreys continues with his political ambitions, as can be seen by two letters to Governor John Hubbard in 1853. In one letter he writes for a favor for himself. In another, dated February 4th, he writes:

*The office of Consul to Rio has of late years been given to this State, and I am inclined to think, it will be considered the property of this State with the incoming administration. It is one of the best situations in the gift of the President at this time. ...*

*I think if you was disposed to go in for it you could get it in preference to any of the others.*

Sawmills are dangerous work places and, in the heat of the summer of 1853, a boy probably on school vacation is badly injured at the mill:

*Brunswick Telegraph*, July 23, 1853

Boys be careful – A young lad aged 10 years, a son of Mr. Solomon Patterson of this town had his foot shockingly crushed one day last week at Humphreys' Steam mill. He had seated himself upon a log in such a position that his foot was caught on the return carriage and bad piece, and thus passed thru a space not exceeding half an inch in width. – Notwithstanding the foot was so terribly crushed, Dr. Lincoln thinks that he will avoid the necessity of amputation, but fears are entertained that the boy will always be a cripple. (1)

Humphreys' stature in Brunswick can be judged by the fact that its citizens appoint him to write a letter to Senator Hannibal Hamlin, chairman of the Senate Commerce Committee, concerning the annexation of Cuba (Demeritt 20). This subject is a very hot topic of the time, especially for Maine shipbuilders and owners, who stand to lose significant money on their voyages.

In 1854 he builds his next ship, which he names *Marengo*. She is slightly smaller, but now he is listed as both builder and owner. She seems to develop a somewhat regular route. The *Brunswick Telegraph* of January 22,

1858 reports that *Marengo* has arrived in Liverpool from Charleston, December 29 (3). She sails from Liverpool for Havana on January 19, 1858. Joseph Tucker in a January 5, 1859, letter to his father in Wiscasset mentions that he has seen *Marengo* heading to Liverpool with a load of cotton. Abby Pennell writes in her June 1, 1859, diary entry, while on the *William Woodside* in Havana, of visiting Captain Doughty of the *Marengo* (Coffin 112). A *Brunswick Telegraph* article, July 25, 1862, states that *Marengo* left Huelva (near Seville, Spain) bound for Liverpool and has been abandoned at sea with the crew saved (3).

Communications with ships at sea had never been speedy or sure. Letters to captains were not received until a ship was actually in the port to which it was sailing. Outgoing mail had to wait until the ship arrived in port, or in rare circumstances might be passed to another ship met at sea. Communications greatly improved in January of 1854 when Brunswick got its first telegraph office. This same year, after graduating from school in Farmington, Denny comes back to the family business and begins working in the shipyard (Humphreys Genealogy 12).

According to the Wheelers, J. C. Humphreys was one of fifteen men who in 1856 formed the Brunswick Mutual Marine Insurance Company. It had a guaranteed fund of \$260,000 but the company had to make three assessments, and by 1865 it was bankrupt (577).

In 1856 Humphreys builds his largest vessel, which he rigs as a bark. She is 143 feet in length, with just over a 30-foot beam and a draft of 15 feet. She is *Annie Kimball* and is built by John Kimball. The April 10, 1857 *Brunswick Telegraph* reports that on February 5, 1857 she is headed from New Orleans to Gottenburg (2). The next year, on February 19, 1858, she is reported to be sailing the Boston-to-New-Orleans route, with J. C.'s 19-year-old son Denny aboard (3).

*Annie Kimball* is the vessel on which Denny first ships out. He starts his maritime career in 1857 as cabin boy under Captain Stinson and sees Glasgow, Genoa, and Huelva, Spain, as well as many American ports. He works his way up to mate and in 1863 he becomes her captain (Humphrey Genealogy 12). There are exciting times ahead for this sailor and we have his logbook for two years as captain of *Annie Kimball*.

In 1857 J. C. becomes a member of a committee of six to investigate "all matters having to do with the town commons title, boundaries, and encroachments" (Wheeler 526). His financial troubles start this year, with multiple lawsuits brought against him and his company for various short-term unpaid debts. In one suit, he is summoned to appear before the Supreme Judicial Court, Portland, for a \$530 debt to Harvey Otis of Brunswick. The

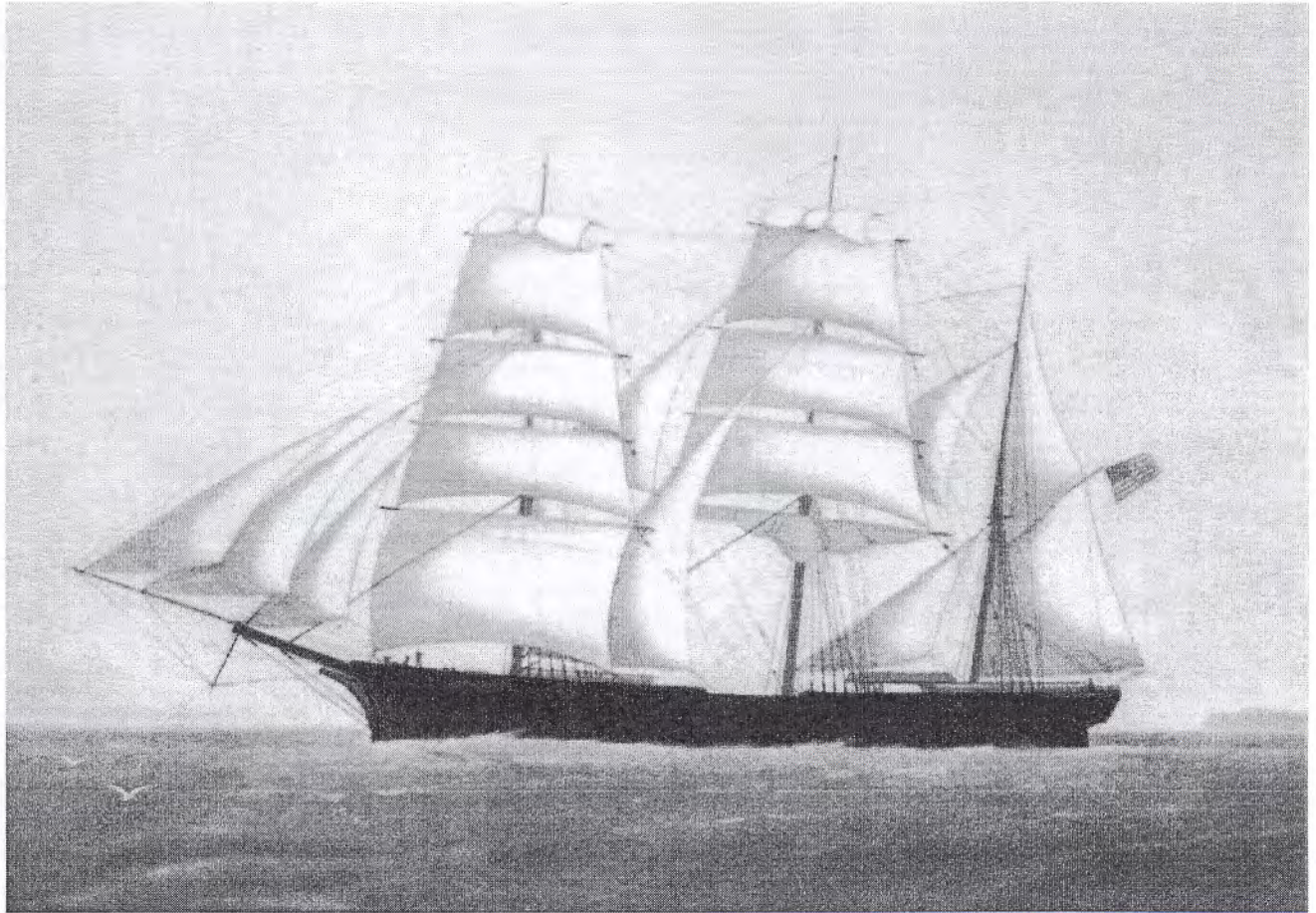

**Above: Copy of William Lincoln's oil painting of bark *Annie Kimball* (courtesy of Robert Michael Jr.). Lincoln served as first mate under Capt. Denny Humphreys.**

sheriff is ordered to attach his goods and estate for \$1,000, but the outcome of the case is unknown (Cumberland County). Throughout 1857 he also owes a total of \$2,700 to John Lynch & Co. of Portland and William J. Harmon, who also take him to court to recover their money. The case appears to be settled in 1859 for \$1,240 plus court costs (Lynch v. Humphreys). These events are likely tied to the panic of 1857 that may have caught Humphreys carrying too much debt. This worldwide economic downturn fell heavily on the northeastern United States, and lasted almost until the start of the Civil War.

*Brunswick Telegraph*, April 30, 1858

Sawing. Gen. Humphreys stopped running his steam mill some time since, and the stoppage threw a number of men out of employment. ... At the falls there are only four saws, a gang, & three single saws (these being all the saws on this side of the river) at work, and as everyone may well know they are not doing an excessively profitable business at the present time. (2)

**Below: Denny Humphreys, son of J. C. Humphreys (courtesy of Maine Maritime Museum).**



By the 1860 census, J. C. Humphreys is listing himself as a farmer, with his personal estate worth only \$1,000. His mother Elizabeth is still living with the family and is now 92 years old. Mary Cary is listed as a servant, born in Ireland, and Annie Gould is listed as 15 years old and a student.

On January 29, 1863, J. C.'s son Denny marries Caroline Owen, and like many a Maine ship captain and new bride, they take off almost immediately on a voyage (Humphrey Genealogy 12). We have the log of the bark *Annie Kimball* written in Denny's hand, transcribed by his great-great-grandson Robert Michael Jr.

Scarcely a week after the wedding, on February 10, 1863, the couple depart South Street, New York City, on *Annie Kimball* for Buenos Aires. By March 8 they "have got the trades." Summarizing the log for March 9 through March 14: "hard gale ... heavy squalls ... heavy seas ... passing squalls." On April 2 they cross the equator, and on May 13 "at 6 PM came to anchor at entrance of harbor off Montevideo" (Uruguay).

Two months later they have a cargo and on August 13 they depart Buenos Aires, Argentina for Callao, Peru. By September 3 they are rounding Cape Horn. From September 5 through 24, the log reports constant gales, squalls, and storms. Again for the first week of October there are more gales and strong gales, but they make Callao in 74 days.

There are only partial entries for what appears to have been an aborted voyage, but on February 4, 1864, they get under way from Callao towards Barbados. On February 14 Denny writes in the log: "Comes in moderate breeze and fine weather. At 8 AM my wife gave birth to a fine little girl. Both are doing first rate." It is hard to imagine a very expectant mother starting on a long voyage back around Cape Horn. By February 23 Caroline goes back out on deck. In the second week of March Denny writes: "Fresh gale, hard gale from the west with an ugly cross sea. At 5 PM took a sea aboard that carried away the boat on the forward house, stove pipe to the galley, and stove channels off the \_\_\_\_\_ side forward." On March 27 he writes: "made the largest days work ... 244 miles" which is quite good for a ship of that type. He arrives in Bridgetown, Barbados, June 2, 1864.

Back in Brunswick another ship is being built at the yard on the Narrows, but this time J. C. Humphreys doesn't appear to be involved in any way. The vessel is the brig *Perpetua*, and she is slightly smaller than others built at the yard.

*Brunswick Telegraph*, April 15, 1864

Brig Building. On Friday last, we drove to Humphreys Steam Mill to look at the brig, which Mr. Elbridge G. Simpson is building, partly on his own account,



Google map showing voyage of Captain Denny Humphreys from New York to Montevideo to Callao, Peru.

and partly on account of his brother in California. The vessel is to be an hermaphrodite brig of about 350 tons, constructed on a model to carry heavy cargo, with a light draft of water, to run on the Pacific Coast. At the time of our visit, the stern post was up and four frames; quite a gang of men are at work. The timber of which the brig is constructed is of very good quality. (2)

*Perpetua* is launched in September and on the 30th the *Brunswick Telegraph* reports her to be leaving for Baltimore to load for San Francisco (2). She was listed as one of the five largest brigs built in 1864 in the area. She was the last to be built at the yard.

J. C. is now 67 years old and his health is failing. When he started the mill at the Narrows, he and his two sons ran the operation. Now with Denny mostly away sailing the high seas, and his father ill, the yard is leased out. The timing of the lease seems to correspond with Denny being back in Bath, and with J. C.'s illness.

*Brunswick Telegraph*, Sept 30, 1864

The Steam Mill. J. F. Prescott & Sons of Phillips, have leased for one year, (perhaps for a longer period) the steam mill formerly owned by Gen. J. C. Humphreys, and are now running the single saws, in cutting up all kinds of lumber, for the market. The mill has lain idle for 4 or 5 years. (2)

Two weeks after the newspaper story, fire strikes the mill and its flammable contents. The Wheelers report:

At ten o'clock P. M., on Oct. 14, one of Humphrey's steam-mills (the most southerly one) was consumed by fire. The loss was estimated at \$5,000. Partially insured. Lumber valued at \$1,000 and not insured was also destroyed by this fire. (264)

A fire at ten p.m. at a highly combustible lumber mill would surely have lit up the sky. It would not have been possible to notify the fire companies in time to save it, as the mill was two miles out of town. We can probably assume that the two saw mills were not very close together, as the article mentions specifically the southerly one. It is somewhat ironic to remember that for so many years J. C. was so heavily involved in Brunswick's fire department.

From August to September of 1864, *Annie Kimball* sails from Curaçao in the Lesser Antilles to Bath, Maine, with salt. In the second half of November she sails on a short voyage from Bath towards Fort Monroe, Virginia, with hay for the Union horses.

Other voyages of *Annie Kimball* with Denny Humphreys as captain:

April 21–May 3, 1865: Philadelphia towards Port Royal, Virginia. His father dies June 18.

July 11–July 15, 1865: Port Royal towards Boston

September 11–October 1, 1865: Boston towards New Orleans

November 10–December 24, 1865: New Orleans towards Liverpool. On this voyage he is able to rescue the captain and 21 crew members of the ship *Harry of the West*, which had caught fire. He transfers that crew to two passing ships and, still later on this voyage, rescues the crew of a waterlogged brig that had ten feet of water in her hold.

February 17–April 13, 1866: Liverpool towards Mobile

June 12–July 29, 1866: Mobile towards Le Havre

September 8–October 23, 1866: Havre towards New York

At the end of this voyage Denny Humphreys turns over *Annie Kimball* to his first mate and returns home to Brunswick. In 1873 *Annie Kimball* is reported sold to J. S. Tumulty of Liverpool for £3,200 (Humphreys Genealogy 12). The *Bath Times* reports on April 1, 1875 that she is brought to St.

Vincent in the Cape Verde Islands, derelict, but in fairly good condition.

For the last few years of his life J. C. Humphreys suffered from asthma. In the winter of 1864 he traveled south for relief, and to try to improve his health. The following spring he was seen "in his wagon, passing to and fro attending to his Duties," but his health was seriously failing. He died June 18, 1865, in his own bed with his family nearby. He was 67 years old, and the cause of death was listed as dropsy. His obituary in the June 23 issue of the *Brunswick Telegraph* stated that, besides what we already knew, Governor Fairfield had at one time appointed him High Sheriff (1).

John Furbish in his *Facts about Brunswick, Maine* comments on Humphreys' death: "A strong party man of the 'Democratic' party (so called) he had no sympathy with any persons who entertained opinions calculated to injure its success. Pleasant and winning in his manner, he exercised a power over men in his employ, which he turned to political account ... he was emphatically a man of the people ... But he tried to do too much business and failed." (29)

His funeral procession was a large and solemn occasion attended by 125 Masons from all over the state, and followed by many carriages. Hundreds of people stood by his grave for the ceremony at Pine Grove Cemetery in Brunswick (*Brunswick Telegraph* 1). His monument is still the tallest there.

He had lived long enough to know of Abraham Lincoln's assassination, two months before his own death. Just three weeks before Humphreys died the Civil War ended, and I imagine that may have made him somewhat more comfortable in his final days. His wife survived him only a short time, and died October 14, 1866 (Wheeler 755).

His son Denny continued in his maritime career for a time, eventually settling down with his wife and children in Bath. He had a marine insurance company there and lived until August 1912. Another of J. C.'s sons, John, went on to become a judge, while his brother, Charles, was a Brunswick selectman and state representative (Humphreys Genealogy 9, 12).



Above: Overall view of Humphreys family grave at Pine Grove Cemetery, Brunswick. Below: Close-up of J. C. Humphreys monument at Pine Grove Cemetery, Brunswick.

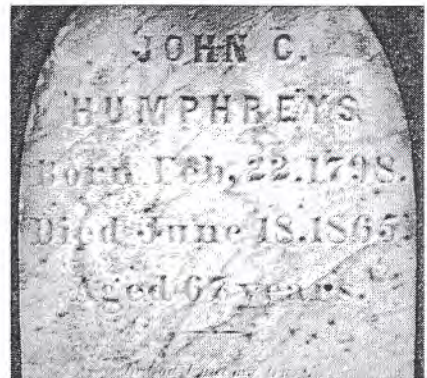



Vessels Built at J. C. Humphreys' Shipyard

Name	Year	Rig	Tons	Length	Beam	Draft
<i>Ophir</i>	1848	ship	438	122'	28'2"	14'1"
<i>J. C. Humphreys</i>	1849	ship	533	139'9"	29	14'6"
<i>Singapore</i>	1851	ship	623	141'1"	31'1"	15'6"
<i>Marengo</i>	1854	ship	567	130'	29'10"	14'11"
<i>Annie Kimball</i>	1856	bark	598	143'	30'2"	15'1"
<i>Perpetua</i>	1864	brig	336	122'9"	29'11"	10'2"

The data in this table, also used at various places in the text, is from William Armstrong Fairburn's *Merchant Sail*.

Today with global positioning systems and satellite communication, it is difficult to imagine how a man might sail off in a wooden ship, hauling hundreds of tons of valuable cargo with just a compass and sextant. The average-size ship built in Humphreys' yard would have carried a cargo the equivalent capacity of approximately 19 large tractor-trailer trucks. These ships criss-crossed the oceans dealing in whatever there was to trade, be it lumber, coal, cotton, ice, hay, or guano, with the captain responsible for all the financial dealings in the local currency of each port, but rooted in our own Brunswick economy.

Men of that time would routinely leave port without knowing when and if they might return, due to the variables of weather, cargo availability, sickness or injury, treachery en route, or any one of many unforeseen problems.

I live downstream of the yard, close enough that the sound of ship construction and sight of smoke from the wood-burning steam boilers would have been evident from my home. The sight of a large ocean-going wooden sailing ship passing by my water-front lawn is still hard for me to envision.



To quote the early 20th-century English historian G. M. Trevelyan:

More generally I take delight in history, even its most prosaic details, because they become poetical as they recede into the past. The poetry of history lies in the quasi-miraculous fact that once, on this earth, once on this familiar spot of ground, walked other men and women, as actual as we are today, thinking their own thoughts, swayed by their own passions, but now all gone, one generation vanishing after another, gone as utterly as we ourselves shall shortly be gone, like ghosts at cock-crow.

What of "Humphreysville" is left in the year 2009? There is a cellar hole that, according to the map, is in the correct place to have been the boarding house. There is a small well that might have been used to supply the water for the steam boilers. There is a large granite base for a part of the mill or boiler and a large pile of bricks to one side of it. The shipbuilding ways were in what is now, and probably was then, a small stream. The stream was dammed up and allowed to dry to create the ways. It has a stone wall of sorts on one side that may have been used as the base for supports to keep the ship upright as it was being built. There are two large hand-wrought pins in the ledge next to the shore, where ships could tie up after launching or for loading. So far, that is all that has been found.

**Shipbuilding ways as seen today**



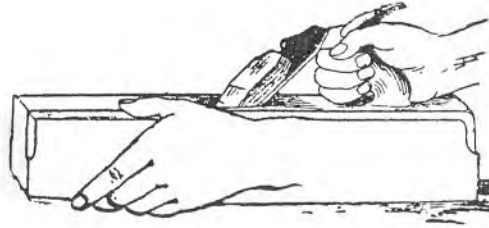

**F**urther information concerning shipbuilding at the Narrows before the early 1800s:

*Brunswick Telegraph*, July 23, 1898

Merrymeeting Park. The land where Merrymeeting Park is located was taken up by Ebenezer Stanwood in 1717 and remained in the family for more than a hundred and thirty years. He was an officer in the Indian wars. His son, David lost an arm at the capture of Louisburg in the French and Indian war and his grandson, Col. Wm. Stanwood was an officer in the revolutionary war, and the second wealthiest man in Brunswick in the early part of the present century. He erected and resided in the house now occupied by Dr. Palmer. He built quite a number of vessels at the Narrows, among them the Brig *Hope* which was captured by the French in 1798, and paid for by the French government in 1834 and the proceeds divided among the heirs of the original owners two years since (1).

*Brunswick Telegraph*, October 26, 1898

We Built Ships. Previous to the Revolutionary War, Benjamin Stone and Capt. John Dunlap built vessels in the Cove and at the landing, and soon after the war Col. Wm. Stanwood built vessels at Merrymeeting Bay, near the Narrows (1).

*Wheeler's History*, "The brig *Hope* was built in Brunswick by William Stanwood and John Dunlap, a short time previous to 1800" (332).

Also interesting to consider is the 1776 Des Barres chart of Casco Bay that shows a road going from Brunswick, directly to the point of land at the Narrows.

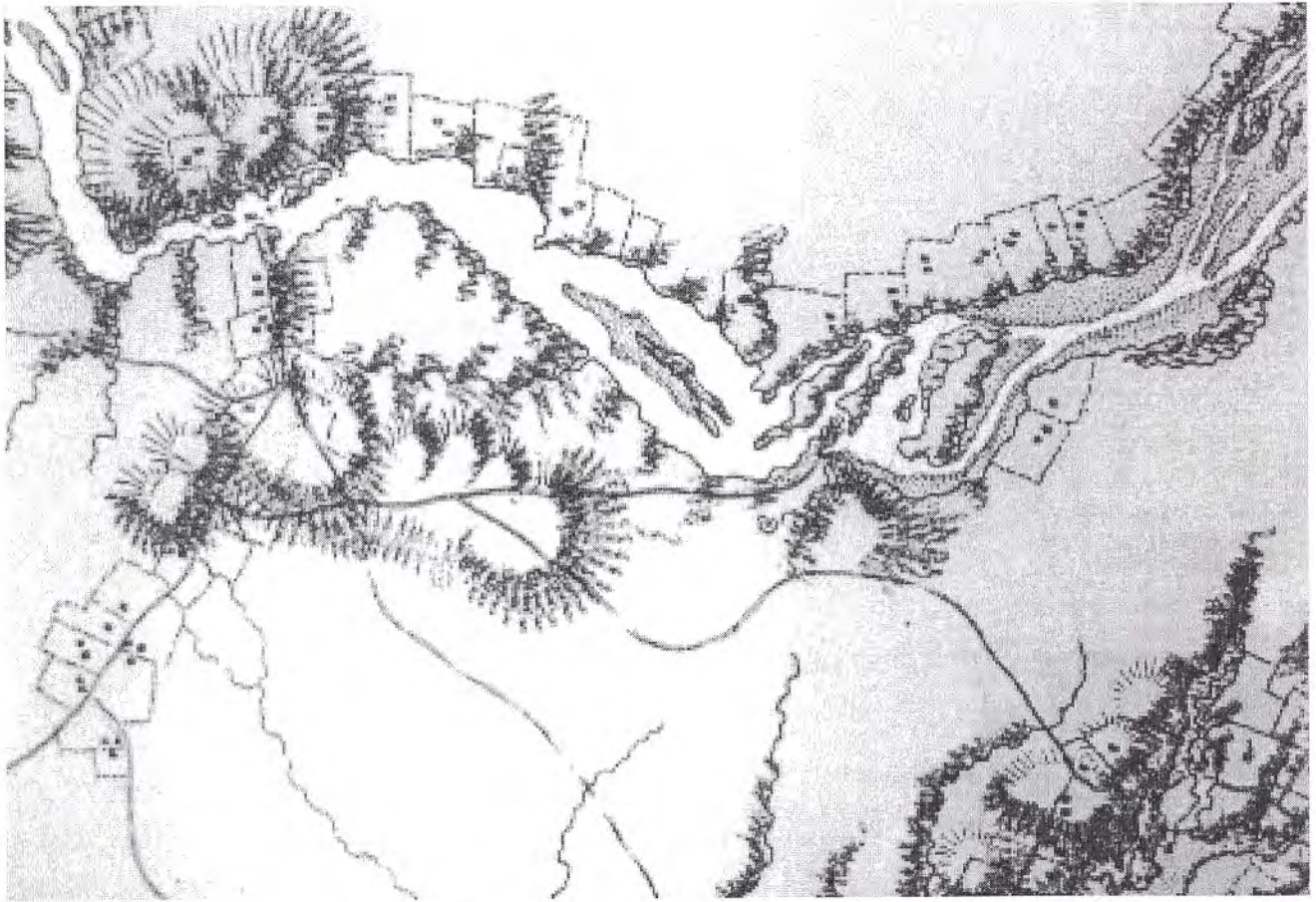

Detail of Des Barres chart of Casco Bay, 1776, showing road going from Maine St., Brunswick directly to what was to become Humphreysville (courtesy private collector)





## LIST OF REFERENCES

### Printed Sources

*Brunswick: A Sketch of the Town.* Brunswick, Me.: E. C. Guild, 1887.

*Brunswick Telegraph:* 1, no. 10, July 23, 1853.  
4, no. 26, Apr. 10, 1857.  
5, no. 5, Jan. 22, 1858.  
5, no. 19, Feb. 19, 1858.  
5, no. 29, Apr. 30, 1858.  
9, no. 42, July 25, 1862.  
11, no. 28, Apr. 15, 1864.  
40, no. 52, Sept. 30, 1864.  
41, no. \_\_, June 23, 1865.  
45, no. 69, July 23, 1898.  
45, no. 96, Oct. 26, 1898.

Coffin, Robert P. Tristram. *Captain Abby & Captain John.* New York: Macmillan Company, 1939.

Cutler, Carl. *Queens of the Western Ocean.* Annapolis, Md.: U. S. Naval Institute, 1961.

Demeritt, David. "Cuban Annexation, Slave Power Paranoia, and the Collapse of the Democratic Party in Maine, 1850-1854." *Maine Historical Society Quarterly* 29, no. 1 (1989): pp. 2-29.

*Eastern Argus* [Portland, Me.]: 48, no. 2494, Jul. 8, 1851  
54, no. 5, Feb. 3, 1857

Fairburn, William A. *Merchant Sail.* Center Lovell, Me.: Fairburn Marine Education Foundation.

Furbish, John. *Facts about Brunswick, Maine.* Brunswick, Me.: Pejepscot Historical Society, 1976.

- Gutscher, Chris. *Very Truly Yours J. C. Humphreys*. Monmouth, Me.: Monmouth Press, 1991.
- Hatch, Louis C. *Maine: A History*. New York: The American Historical Society, 1919.
- Matthews, Frederick C. *American Merchant Ships: Series Two*. Salem, Mass.: Marine Research Society, 1931.
- New York Times*, 3, no. 732, Jan. 21, 1854.
- Our Town: Reminiscences and Historical Studies of Brunswick, Maine*, edited by Louise R. Helmreich. Brunswick, Me.: [s. n.], 1967.
- Rowe, Henry H. *Shipbuilding Days in Casco Bay*. Freeport, Me.: Bond Wheelwright, 1966.
- Wheeler, George A., and Henry W. Wheeler. *History of Brunswick, Topsham, and Harpswell*. Boston: Alfred Mudge & Son, 1878.

#### Correspondence and Documents

- Andrews, Charles. Letter to J. C. Humphreys, 8 Aug. 1848.  
Miscellaneous Manuscript Collection, George J. Mitchell Department of Special Collections and Archives, Bowdoin College, Brunswick, Maine.
- Brunswick Selectmen Petition. Brunswick Town Reports, vol. 4, p. 364,  
Town of Brunswick, Brunswick Town Hall, Brunswick, Me.
- Brunswick Tax Records, 1834, Misc. vol. 58  
1842, 1919.103.25, Misc. vol. 58  
1848, 1981.97, Misc. vol. 109  
Town of Brunswick, Brunswick Town Hall, Brunswick, Me.
- Clapp, Asa William Henry. Letter to General J. C. Humphreys, 20 Dec. 1847.  
Miscellaneous Manuscript Collection, George J. Mitchell Department of Special Collections and Archives, Bowdoin College, Brunswick, Maine.
- Cumberland County, Office of the Sheriff. Sheriff's Writ, 25 Nov. 1857.  
Maine Supreme Judicial Court Records. Cumberland County Courthouse, Portland, Maine.
- Ficken, Homer R. "German Settlement of the Cole Camp Area,"  
MOGenWeb Project, <http://www.phelbs.com/hrftx/Germans.htm>.
- Humphreys, Denny McCobb. "Log of the Bark *Annie Kimball*, D. M. Humphreys, Master,  
February 10, 1863 to October 23, 1866."  
Transcribed by Robert Michael, Jr., July 1995. Private collection.
- Humphreys, John C. Letter to John Hubbard, 1 Feb. 1853.  
4 Feb. 1853.  
Undated.  
Hubbard Family Papers, George J. Mitchell Department of Special Collections and Archives, Bowdoin College, Brunswick, Maine.

Humphreys, John C. Letter to Silas Pierce, 9 Dec. 1845. Pejepscot Historical Society, Brunswick, Maine.

"Humphreys Genealogy." Unpublished typescript, Mar. 26, 1996. Private collection.

Janus, Jardine Matheson Archive, Cambridge University Library,  
<http://janus.lib.cam.ac.uk/db/node.xsp?id=EAD%2FGBR%2F0012%2FMS%20JM%2FMS.JM%2FF7%2F33>.

Lynch v. Humphreys, 447 Me. 102 (Jan. 1859).

McCobb, Denny. Letter to Gen. Humphreys, 15 Feb. 1845.  
Miscellaneous Manuscript Collection, George J. Mitchell Department of Special Collections and Archives, Bowdoin College, Brunswick, Maine.

Militia Records: Humphreys, John Campbell.  
Maine State Archives, Augusta, Maine.

Tucker, Joseph. Letter to Richard Hawley Tucker, 5 Jan. 1859.  
Tucker Shipping Papers, George J. Mitchell Department of Special Collections and Archives, Bowdoin College, Brunswick, Maine.

U. S. Census Bureau. The Sixth Census of the United States: 1840 [Schedules]  
The Seventh Census of the United States: 1850 [Schedules]  
The Eighth Census of the United States: 1860 [Schedules]



For further reading:

Rivard, Paul E. *Maine Sawmills, A History*. Augusta, Me.: Maine State Museum, 1990.

